

Kuwaiti Chemical Leader Reduces Variability, Optimizes Performance in Ammonia Production

PIC deploys aspenONE® Advanced Process Control—featuring the Aspen DMCplus® controller—to reduce variability across ammonia lines up to 75%.

In 1964 Petrochemical Industries Company (PIC) established the Kuwait Chemical Fertilizer Company (KCFC), the first chemical fertilizer complex in the region. KCFC was comprised of four plants, which produced ammonia, urea, ammonium sulfate, and sulfuric acid.

Since that time, PIC's plants have expanded and new plants have been installed, including three plants for liquid ammonia and two for urea, making the production capacity of PIC's ammonia and urea complex the largest in the Middle East.

The scale of PIC's operations presented a number of challenges:

- Severe disturbances in natural gas density
- Interconnections between Line-4, Line-2, PGRU, and ammonia absorption units
- The need for manual operation of compressors in ammonia Line-2
- No direct control of feed gas or process air flows for Line-2

PIC selected Aspen DMCplus to address these challenges, and implementation has improved control of their ammonia lines, significantly maximizing production.

Customer Profile

PIC
Chemicals

Challenge:

Reduce variability in ammonia production

Solution:

Deployment of Aspen DMCplus for improved control of the ammonia lines

Benefits:

- Reduce variations in the CH₄ slip by approximately 50 percent
- Reduce variability in excess O₂ by 75 percent
- Reduce variability in the primary reformer outlet temperature by 60 percent
- Improve plant stability and process conditions maintenance for ease of operation



APC Provides Effective Disturbance Rejection for Variability

The design of the controllers for the boilers/super-heaters and the high- and low-capacity ammonia lines included two Aspen DMCplus controllers:

- **Ammonia Controller:** This controller covers MEA absorption, reforming, shift conversion, CO₂ removal, methanation, synthesis sections of both ammonia trains (e.g., Line-2 and Line-4), and PGRU and ammonia absorption units.
- **Steam Controller:** This controller covers all boilers and super heaters that are under control of Ammonia Line-4 and Ammonia Line-2. These include four boilers and three super heaters.

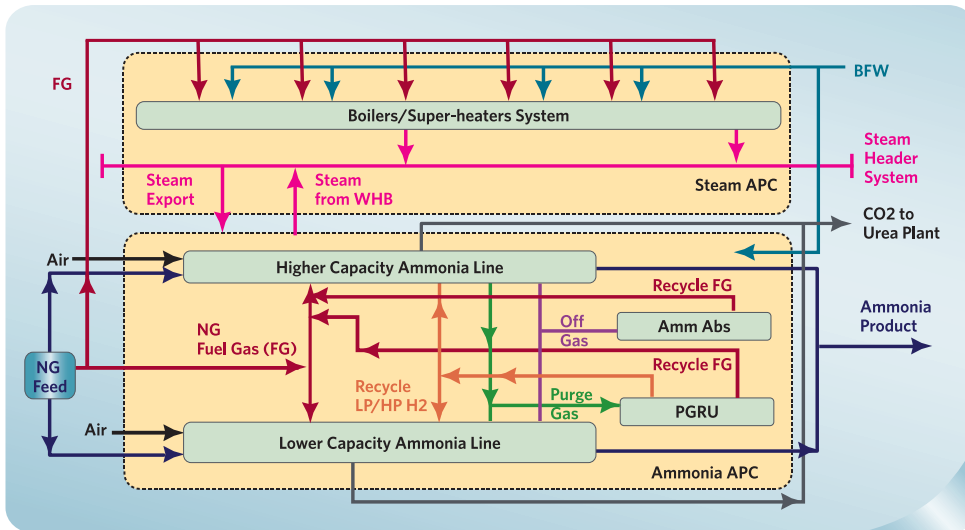

PIC's implementation of Steam and Ammonia controllers

This design delivered effective control of the plant against disturbances in feed NG density while minimizing the steam-to-carbon ratio of the reformer feed mix. Other improvements include the minimization of synthesis gas vent and stabilization of reformer outlet temperature.

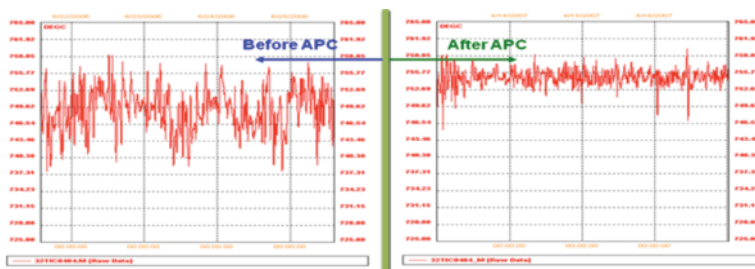

Ammonia Line-4 and stabilization of primary reformer outlet temperature, which is controlled within (+/-) 2 degrees, representing about 60% reduction in variability.

About AspenTech

AspenTech is a leading supplier of software that optimizes process manufacturing — including oil and gas, petroleum, chemicals, pharmaceuticals and other industries that manufacture and produce products from a chemical process. With integrated aspenONE solutions, process manufacturers can implement best practices for optimizing their engineering, manufacturing and supply chain operations. As a result, AspenTech customers are better able to increase capacity, improve margins, reduce costs and become more energy efficient. To see how the world's leading process manufacturers rely on AspenTech to achieve their operational excellence goals, visit www.aspentech.com.



Worldwide Headquarters

Aspen Technology, Inc.
200 Wheeler Road
Burlington, MA 01803
phone: +1-781-221-6400
fax: +1-781-221-6410
info@aspentech.com

EMEA Headquarters

AspenTech Ltd.
C1, Reading Int'l Business Park
Basingstoke Road
Reading, Berkshire
RG2 6DT United Kingdom
phone: +44-(0)-1189-226400
fax: +44-(0)-1189-226401
ATE_info@aspentech.com

APAC Headquarters

AspenTech (Shanghai) Co., Ltd.
3rd Floor, North Wing
Zhe Da Wang Xin Building
2966 Jin Ke Road
Zhangjiang High-Tech Zone
Pudong, Shanghai
201203, China
phone: +86-21-5137-5000
fax: +86-21-5137-5100
apac_marketing@aspentech.com